





12 SERIES

<http://tiny.cc/12seriesEN>

 TIPPING LOAD 1530¹ kg	 ENGINE POWER 40 hp	 SPEED 20² km/h	 FLOW RATE 52 l/min	 LIFT HEIGHT 3,45² m
--	--	---	--	--

(1) 12.4 - (2) 12.4T 2V



Model	12.4	12.4 2V	12.4 T	12.4 T 2V
Engine	Yanmar 3TNV88			
Power (Iso Gross)	40 HP			
Fuel	Diesel			
Transmission	Hydrostatic			
Drive speed (max.) (1)	13 km/h (8 mph)	Double speed: 10 - 20 km/h (6.2 - 12.4 mph)	13 km/h (8 mph)	Double speed: 10 - 20 km/h (6.2 - 12.4 mph)
Boom	Standard	Standard	Telescopic	Telescopic
Aux. hydraulics oil flow	52 l/min (13.7 GPM)			
Max. lifting height	2,4 m (94.5 in)		3,45 m (135.8 in)	
Tipping load, max (2)	2009 kg (4430 lbs)		1349 kg (2974 lbs)	
Lifting capacity (3)	1439 kg (3172 lbs)		1259 kg (2775 lbs)	
Breakout force / 50 cm w/bucket	1750 kg (3858 lbs)		1840 kg (4056 lbs)	
Pushing force (c)	1900 kgf (1900 kp)			
Specific ground pressure (w/std tires)	1121 kg/m ² (230 lbs/sqft)		1186 kg/m ² (243 lbs/sqft)	
Turning radius: inside/outside	1200 / 2437 mm (47.2/95.9 in)			
Standard tires (Skid profile)	27x8.50-15			
Weight	2075 kg (4575 lbs)		2195 kg (4839 lbs)	
Product Code	C985400	C985410	C985420	C985430

(1) Maximum speed that can be achieved with the largest diameter tires available, on a flat surface and machine without attachments.

(2) Maximum load that can be lifted just off the ground when the machine is straight. Weight of attachment included.

(3) Machine straight and boom not extended. Weight of attachment is included (80% of tipping load).

12 SERIES - FEATURES

- 4WD hydrostatic Direct Drive motors, proportional servo control
- Self-levelling boom
- Dual steering system: all-wheel and crab
- Multi-functions joystick
- Multi-disk parking brake
- Radial Piston high efficiency and heavy duty wheel motors
- Hi-Flow system (optional)
- Hydraulic multiconnector
- 2 Speed (only 2V model)
- Hydraulic oil cooler

- ROPS-FOPS Level I
- LCD graphic display with programmed service (tachometer, hour meter, fuel gauge, maintenance light, light indicator and other 14 indicators)
- Ergonomic full adjustable suspension seat with armrest and seat belt
- 2 front working light
- Ready to fit cabin
- Backup warning beeper

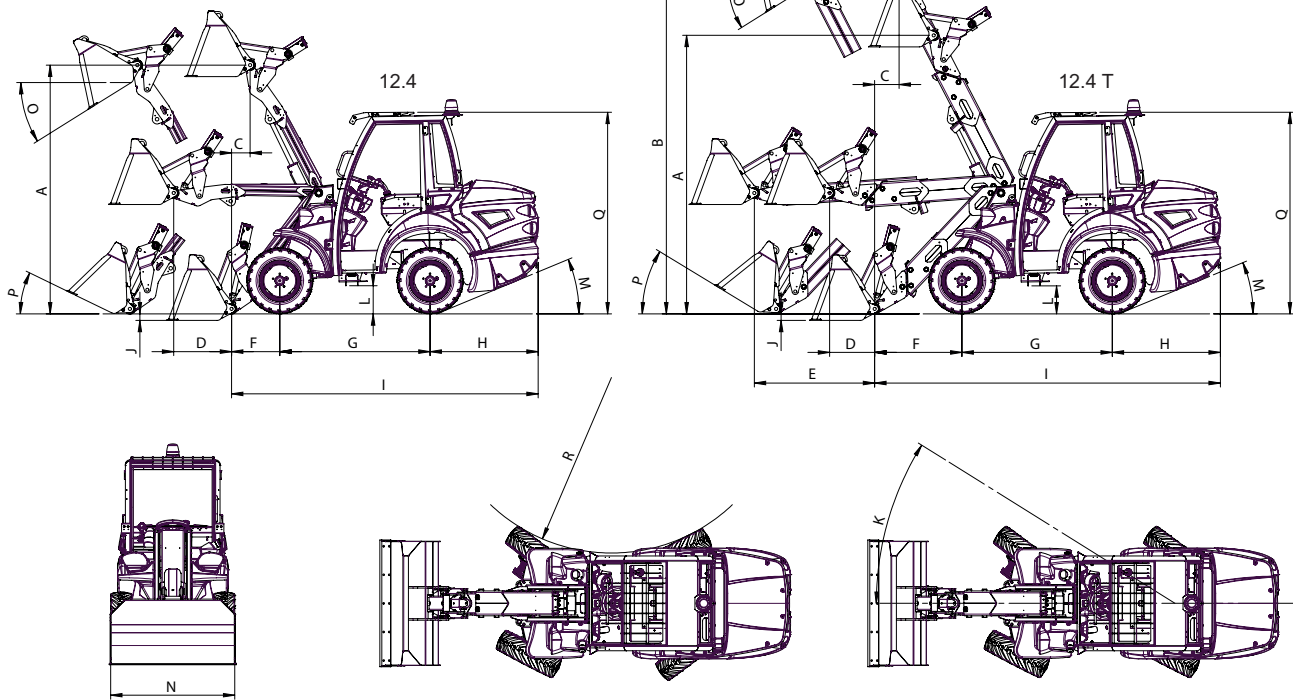

DIMENSIONS (mm / in)

	12.4	12.4 T		12.4	12.4 T
A - Pivot point height (not ext. boom)	2375 / 93.5	2800 / 110.2	K - Steering Angle	32°	
B - Pivot point height (ext. boom)	/	3450 / 135.8	I - Machine length	3015 / 118.7	3460 / 136.2
C - Outreach (lifted boom)	178 / 7	244 / 9.6	L - Ground clearance	280 / 11	
D - Outreach (orizental boom)	450 / 17.7	450 / 17.7	M - Angle of departure	22°	
E - Outreach (ext. orizental boom)	/	1200 / 47.2	N - Max width (std tires)	1237 / 48.7	
F - Front length	416 / 16.4	870 / 34.2	O - Dump angle	32°	
G - Wheelbase	1490 / 58.7		P - Rollback angle	26°	
H - Rear length	1100 / 43.3		Q - Height (std tires)	2000 / 78.7	
J - Digging Depth	160 / 6.3	65 / 2.6	R - Inside turning radius	1200 / 47.2	

Tires size	Width (N)	Height (Q)
27X10.50-15	1287 mm (50.7 in)	2000 mm (78.7 in)
10-16.5	1280 mm (50.4 in)	2070 mm (81.5 in)
400/50-15 (31x15.50-15)	1580 mm (62.2 in)	2055 mm (80.9 in)

12 SERIES - OPTIONS

Options	Code
110 V engine block heater	C885255
220 V engine block heater	C885250
Adapter plate to connect mini loader MultiOne attachments	C890025
Beacon light	C883039
Biodegradable oil	C883007
Flat face coupling kit	C880221
Fully enclosed cab with heating system and mirrors	C882006
Heated seat	C885015
Heating system	C882008
Hi-Flow kit for Standard Boom (only for C985400 and C985410)	C882003
Hi-Flow kit for Telescopic Boom (only for C985420 and C985430)	C882007
Rear hydraulic outlet	C882004
Rear inner weights 100 kg/220 lbs	C882009
Skid tires 10-16.5, set of 4	C883106
Skid tires 27x10.50-15, set of 4	C884012
Snow chains for wheel	see page 69
Tie down bracket on wheel hub, set of 4	C883065
Tractor tires 400/50-15 (31x15.50-15), set of 4	C884015
Trailer Coupling	C882002
Turf tires 400/50-15 (31x15.50-15), set of 4	C884014
Wheel spacer 10 mm (0.4 in), set of 4 (max. 1 pcs for wheel)	C880090
Warning & Safety lights for road travel (with mirrors)	C882001

GENERAL BUCKET FOR 12 SERIES

FEATURES & BENEFITS

- Efficient design
- Heavy Duty construction
- Cutting edge designed for bolt on teeth

The MultiOne bucket design enables good visibility to the cutting edge, making loading, grading, and dumping more efficient. Heavy duty steel construction includes slide wear bars on the bottom of the bucket, and the cutting edge is designed for bolt-on teeth.

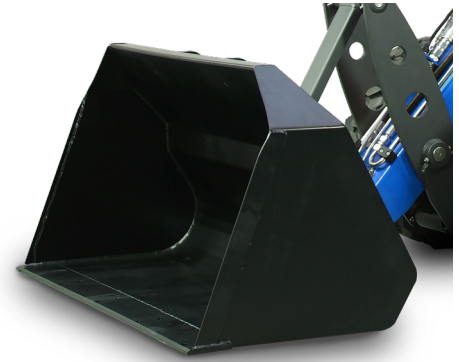

Model	Volume	Width	Weight	Nr. of teeth	Code
125	350 l (12.4 ft ³)	125 cm (49.2 in)	107 kg (236 lbs)	5	C898000
140	410 l (14.5 ft ³)	140 cm (55 in)	120 kg (265 lbs)	6	C898001
165	470 l (16.6 ft ³)	165 cm (65 in)	142 kg (313 lbs)	7	C898002
Accessories				Weight	Code
Tooth				1,7 kg (3.7 lbs)	C890007

COMBO BUCKET FOR 12 SERIES

FEATURES & BENEFITS

- Heavy Duty construction
- Hydraulic locking valve for load holding
- Multiple functions: digging, dozing, grading, grappling, and dumping

This multi-purpose bucket enables can be used for demolition, landscaping, and general construction work. When used as a grapple, the dual cylinders, equipped with load holding valves, provide a secure clamping force. Open the bucket for fine grading. In dumping operations, loading height is increased by opening the bucket. Heavy duty steel construction includes a cutting edge.

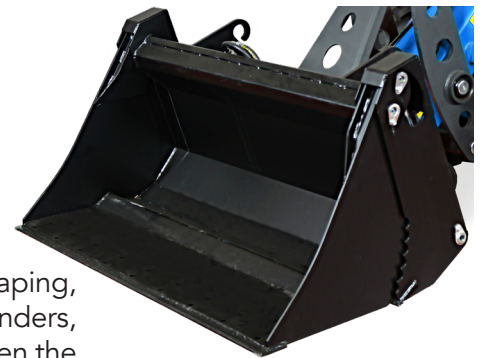

Model	Width	Volume	Height	Weight	Code
140	140 cm (55.1 in)	375 l (13.2 ft ³)	65 cm (25.6 in)	295 kg (650 lbs)	C898121

SNOW BLOWER FOR 12 SERIES

FEATURES & BENEFITS

- Efficient two-stage snow blowers
- Heavy duty frame and transimission with replaceable cutting edge

The snow blower is an efficient method to remove large amounts of snow from sidewalks, roads, or other large areas when snow needs to be spread out evenly. The two-stage blower provides a powerful and efficient snow removal tool, even if the snow is wet and heavy. To achieve this efficiency, the auger breaks up the snow and the fan throws the snow out of the discharge chute. The chute can be rotated 200° from the operator's seat, with the discharge chute height angle manually adjusted.

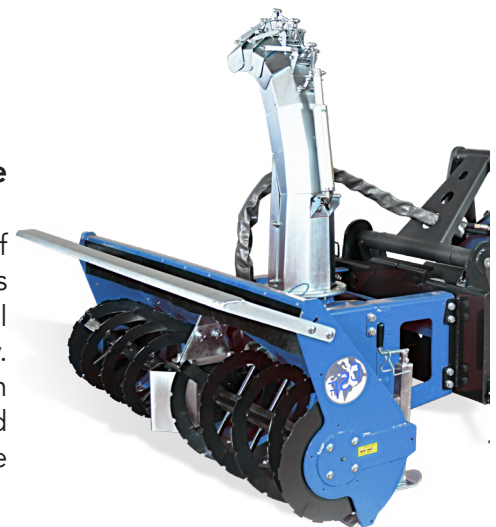

Model	Width	Chute Rotation	Weight	Code
140	140 cm (55.1 in)	200° (±100°)	220 kg (485 lbs)	C890469

PALLET FORK FOR 12 SERIES

FEATURES & BENEFITS

- **Must-have attachment**
- **Heavy duty construction**
- **Easily adjustable fork width**

The quick attach pallet fork enables safe and quick handling of multiple sized pallets.

The forks are forged from high strength steel, and are available in several lengths based on model size. The fork frame is designed to allow the width of the forks to be easily adjusted by as much as 1 m (39 in).

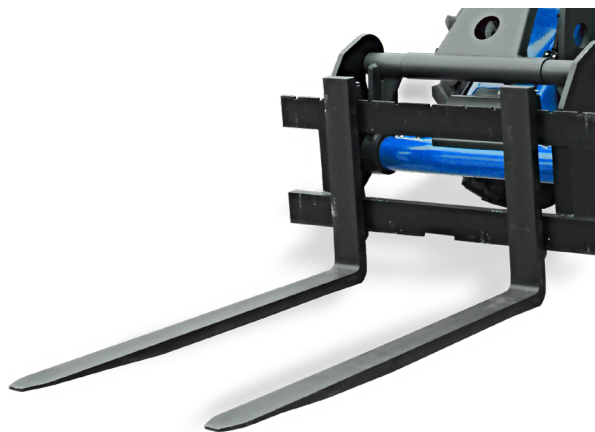

Model	Forks Length	Max Forks Width	Lifting Capacity	Weight	Code
110	110 cm (43.3 in)	100 cm (39 in)	1000 kg (2204 lbs)	180 kg (397 lbs)	C898060

SILAGE FORK FOR 12 SERIES

FEATURES & BENEFITS

- **Heavy duty frame**
- **Versatile and efficient**

The multi-purposed silage fork, in combination with the frame top hydraulic clamp, makes moving loose or baled silage safe and easy. The extra strength framework allows heavy loads, like round bales and more, to be safely and effectively moved.

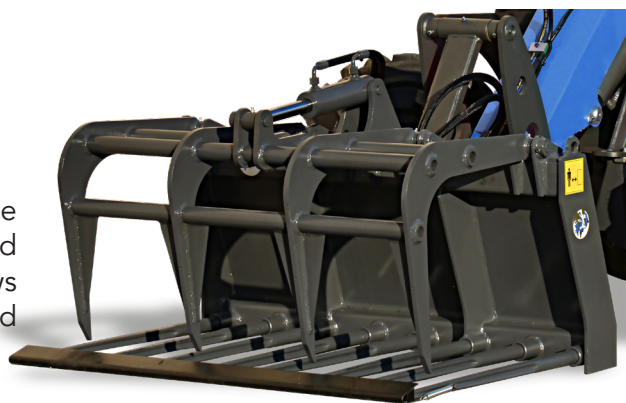

Model	Width	Weight	Code
125	125 cm (49.2 in)	195 kg (430 lbs)	C898150

SWEEPER FOR 12 SERIES

FEATURES & BENEFITS

- **Powerful sweeper for large areas**

This attachment quickly and quietly sweeps and collects dirt and debris, and easily dumps out the refuse. Perfect system for cleaning parking lots, sidewalks, loading docks, warehouses, and more.



Model	Working Width	Volume	Weight	Code
155	155 cm (61 in)	480 l (17 ft ³)	397 kg (875 lbs)	C898100